

The industry leader in  
technical design support  
utilizing structural aluminum and  
modular components in factory  
automation, manufacturing  
and assembly operations

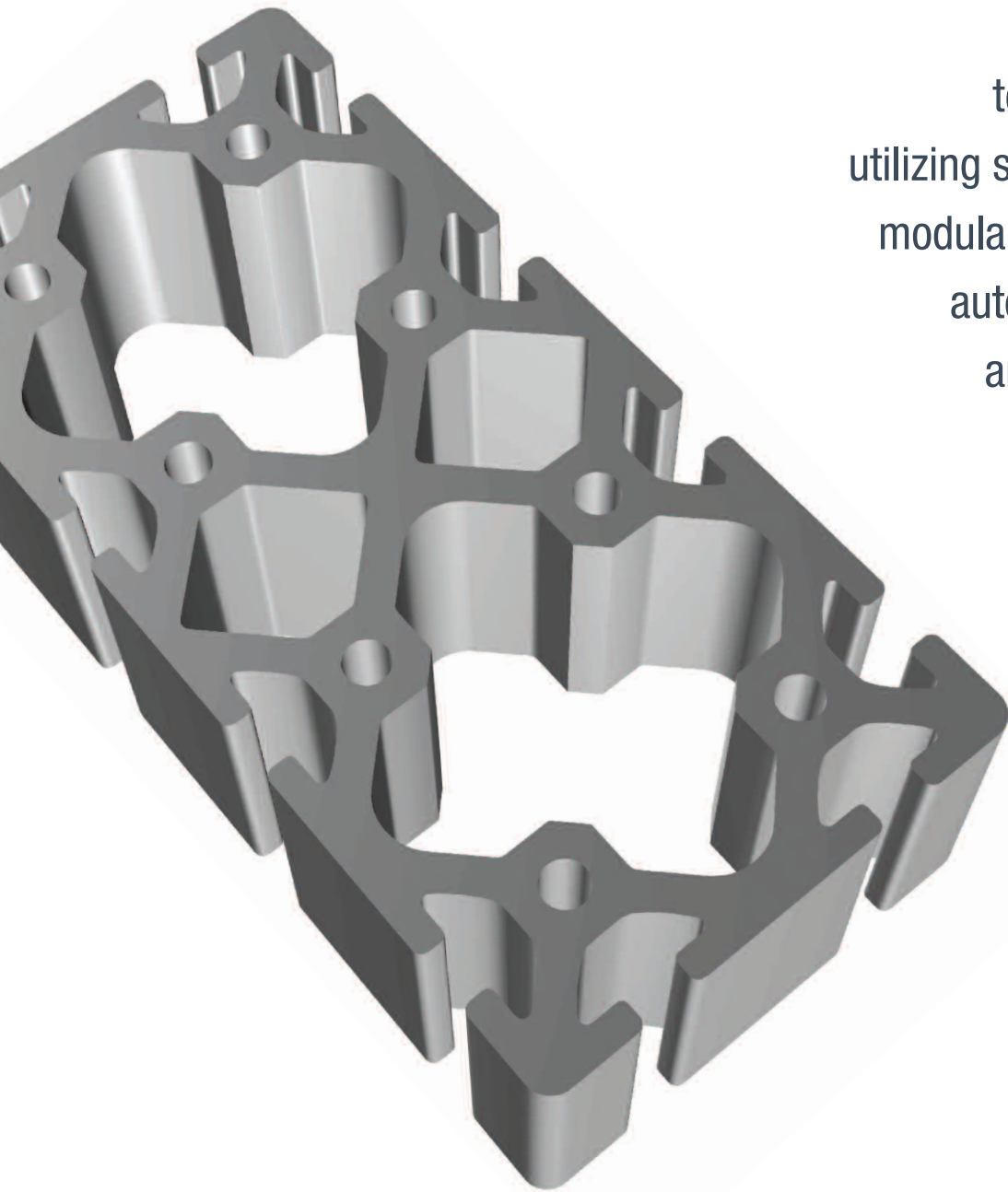



# Welcome to **item**<sup>®</sup> North America

---

**item** North America is the industry leader in technical design support utilizing structural aluminum and modular components in factory automation, manufacturing and assembly operation processes.

As the “originator” of the structural aluminum machine building system, item has over thirty years of experience designing systems to increase efficiency, improve appearance and create flexibility in production environments.

**item's** extensive product line allows for engineering to exact customer specifications using “off the shelf” components to create a custom design specifically for each application.

Precision structural aluminum profiles and modular components allow for easy integration of linear motion, from the simplest X-Y movement to extremely complex, multi-axis pick & place robots or material handling equipment.

**item's** world wide presence assures that modifications, re-configurations or additions to your structural aluminum project can be done quickly and easily utilizing a standard global parts numbering system.

**item's** Akron Ohio headquarters and multiple North American distribution and service center locations can assist in all phases of planning, design and implementation of your next structural aluminum application.



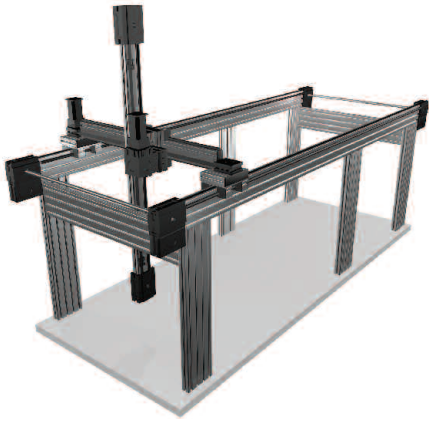

## Scope of the Product

**item** structural aluminum and modular components can be used to replace welded steel in many applications. New design and fastener technology results in joints that are as strong as welded steel yet weigh significantly less.

Precision **item** extrusions allow for the use of hardened steel shafts in many of our T-slot surfaces, allowing for a modular approach when creating single, dual or multiple axis linear actuators. Unique designs and fasteners allows **item** to create linears up to and greater than 100 feet in length.



## Engineering Services

**item's** greatest strength lies in the depth and experience of our in-house engineering department. **item** engineers are highly trained in the use of structural aluminum to create a hardware solution which is designed for your exact specification. We do not over-engineer or under-engineer your application. **item** engineers choose from over 320 different profiles and use those which best meet the specifications that you provided.

Generally, we can provide an AutoCAD or Solid Edge drawing and quote within 5-7 business days of getting your project information.

And the best part of dealing with **item's** engineering services? All design and engineering assistance provided by **item** is at no cost to our customers and prospects.



# Quick Delivery

When your design is complete and drawings have been approved, **item** can deliver in three different formats.



## Bulk Products

**item** can ship bulk deliveries within 24-48 hours of getting your order. Our North American headquarters located in Akron, Ohio houses over four million dollars of structural aluminum and modular components. An additional item warehouse located on the east coast insures that large bulk orders can ship anywhere in North America within two days.

## Kit Products

**item** can provide cutting, drilling, tapping and extensive machining services which allow the end user to utilize their own in house labor to assemble kits at the final destination. The purchase of kits results in labor savings, reduction in shop floor space requirements and significant shipping cost savings.

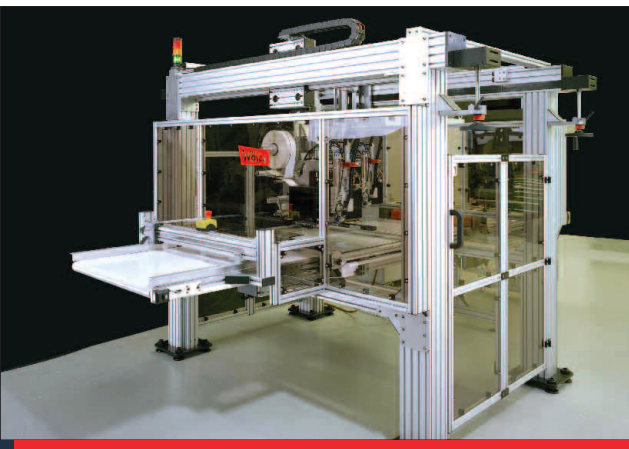

## Fully Assembled or Sub-Assembled Products

**item** can provide a fully assembled project which is ready to go when unpacked in your facility. In the case of very large or complex applications, item can provide sub-assembled products which require very little assembly labor at the final destination.

# Integration or Value Add

**item** North America is not an integration company. We provide value added services resulting in a mechanical or hardware solution to your manufacturing, assembly or automation needs. item North America does maintain a list of integration solution providers who can meet your needs. Contact us at the numbers listed below for an integrator in your area.





## Akron, Ohio Manufacturer

**item's** 15,000 square foot shop and highly trained employees are capable of delivering product to your exact specifications.

Our mechanical staff of twenty employees insures that product is delivered on time, every time. Shop floor production equipment is calibrated on a weekly basis.

**item's** machining and CNC capabilities can provide special services for just about any need. If necessary, local vendors are used when demand exceeds available production time or in-house capabilities.



## Router Services

**item** has recently purchased a high speed MultiCam 5000 series router. This new piece of equipment will allow us to bring panel cutting services in-house, insuring timely delivery of even the most complex enclosures or guarding applications.

The MultiCam 5000 is capable of cutting a wide range of materials up to 1.5 inches thick.



**item**<sup>®</sup>

North America | 925 Glaser Parkway | Akron, OH 44306 | Toll Free: 888-729-4500  
Phone: 330-945-4500 | Fax: 330-945-6440 | [www.itemAmerica.com](http://www.itemAmerica.com) | [itemSales@itemAmerica.com](mailto:itemSales@itemAmerica.com)



## Customer Service Department

**item's** inside sales staff is an excellent source and starting point for all of your technical inquiries. Our inside staff works closely with engineering to insure that all questions are handled promptly and efficiently.

All projects start in our sales department with a completed Application Inquiry. This Application inquiry is the key document which tracks your project as it travels through the item design process.

## **item** North America Specializes in the Design & Build of...

- Guarding & Safety Enclosures
- Heavy Duty Machine Bases
- Work Stations and Lean Assembly Cells
- One, Two, Three and Multi-Axis Linear XYZ Pick & Place Robots
- Linear Actuators Up to and in Excess of 100 Feet
- Ball Screws (5 and 20 pitch) up to 110 Inches in Length
- Auxiliary Packaging Equipment and Roller Conveyors

**item**<sup>®</sup>  
North America

925 Glaser Parkway  
Akron, OH 44306  
Toll Free: 888-729-4500  
Phone: 330-945-4500  
Fax: 330-945-6440

www.itemAmerica.com  
itemSales@itemAmerica.com

This brochure was designed to provide an introduction to item North America and the capabilities of the item Machine Building System. The product breadth combined with item's engineering expertise can provide an entirely new way to look at your next automation, assembly or manufacturing project. For additional information on how item's structural aluminum and modular components can be used in your specific application, contact us at [www.itemAmerica.com](http://www.itemAmerica.com) or toll free at 888-729-4500.